

## Front suspension Cougar- TopCat to Cougar conversion

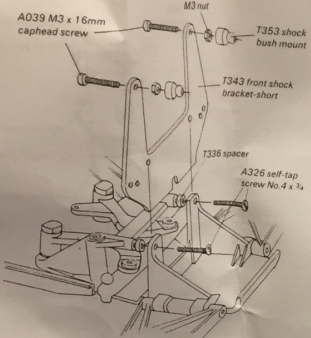

8) Insert the T343 fibreglass front shock bracket into the slot in the lower suspension plate. Secure the whole front suspension unit using A326 T336 spacers as shown. The front suspension rake and caster angle can be adjusted using one or two spacers, or none at all. It is suggested that at first only one spacer is used each side, this gives a rake angle of 20°. Two spacers each side gives a rake angle of 15° and with no spacers the rake angle is 25°. Experiment with rake angle for different track conditions. (see track settings) At the top of the fibreglass front shock bracket fit A039 M3 x 1.6mm caphead screws and secure with M3 nuts. Fit T353 shock bush mounts over each M3 nut as shown.

9) Fit a T321 ball joint stud and nylon washer into the outer hole in the foreground bracket and secure with an M3 nut and threadlock as shown. Repeat for the opposite side. The ball joint stud should face towards the front of the car. Screw a ball joint stud into the outer hole of the righthand steering block. Repeat for the left hand side. Make up the front suspension top links by screwing T320 ball sockets to each end of two A095 M3 x 45mm turnbuckles. These have a right and left hand thread to aid adjustment when fitted on the car. Equilibrate thread engagement and make length approximately 55mm between hole centres. Fit the top links to the ball joint studs as shown. Make up the steering trackrod links in the same way using M3 x 45mm turnbuckles. Fit the steering trackrod links to the ball joint studs as shown. Make the length approximately 61mm between hole centres.

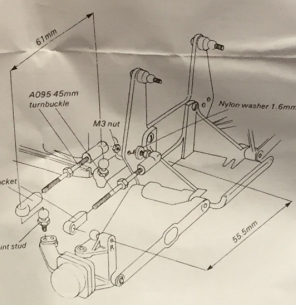

10) Fit the front shock absorbers to the car by fitting the top of the shock absorbers over the T353 shock bush mounts and secure with M3 nylon nuts. Do not overtighten, shock absorber must have free movement over the full range of suspension travel. Insert the rose joint at the base of the shock absorber into the slot in the front wishbone. Fix to the wishbone using an A039 M3 x 1.6mm caphead screw into the inboard of the two holes. (see page diagram - centre pages)

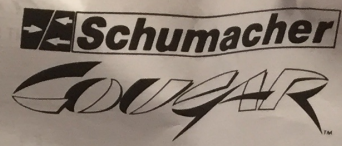

U558N Front Suspension COUGAR (TOPCAT to COUGAR conversion)

This conversion kit will enable the front suspension of a TOPCAT to be replaced by the front suspension of a COUGAR.

The COUGAR Body & Wing Moulding to complete the conversion, is available as U583M.

COUGAR FRONT SUSPENSION - CONTENTS LIST

Part No.	Part Name	Qty	Part No.	Part Name	Qty
U558N	Front Suspension Set - Cougar	1	T343	Shock Mount Bush	2
U562E	Shock Mount Pkg - Cougar	1	A051	Nylon Nut M3	2
U702A	Ball Bearing 8 x 16 x 5	2	U702A	A100 1/8" Dia. Cap Nut	2
T707	Front Suspension Small Parts - Cougar	2	A039	St. Sl. Screw M3 X 1.6 Cap. Hd.	12
U700K	Ball Socket - Small	8	A044	Steel Nut M3	2
U700L	Ball Socket - Large	8	A045	Steel Nut M3	2
A010	Steel Screw M3 X 20 Ph. Hd.	2	U702W	T343 Steering Pivot Set - Cougar	2
A029	St. Sl. Screw M3 X 16 Cap Hd.	4	T342	Front Bush - Steering	2
A046E	Steel Nut M3	4	T342	Steering Lower Pinot	2
A051	Nylon Nut M3	2	A025	Steel Washer M3	2
A038	Screw Self Tap No. 4 X 3/4 Ph. Hd.	2	A020	Steel Screw M3 X 12 CDK Hd.	4
A038	St. Sl. Screw M3 X 1/2 Cap Hd.	2	A020	Steel Screw M3 X 8 CDK Hd.	2
A006	Nylon Washer 2 X 4 X 1/4	2	U704E	Wishbone & Hub Mouldings - Cougar	2
U704H	Turnbuckle Adjuster M3 X 45mm	4	T320	Steering Block	2
A000	Screw Self Tap No. 2 X 1/4 Ph. Hd.	8	T320	Wishbone - Front	2
T708	Chassis Accessories - Cougar	1	T320	Swivel - Rate Angle	2
U715G	Wire Clamp	1	T320	Inner Hub & Nylon Holder	4
A024	Link Wire	2	T320	Steering Nutplate	2
A033	Screw Self Tap No. 4 X 3/8 CDK Hd.	2	U707E	Front Plate & Steering Levers - Cougar	2
U564E	Hub Holder & Drop	1	T340	Lower Suspension Plate	1
A023	Screw Self Tap No. 4 X 3/8 Ph. Hd.	2	T340	Steering Lever	1
U702M	T112 19005	1	U704E	Radius Arm	1
U704E	Serial Top	1	U704E	Top Blk. Taper, Centre Track Rod Coupler	1
U704E	Serial Top	1	T320	Upper Suspension Plate	1
U704E	Serial Top	1	T320	Steering Yoke B. H.	1
T339	Pinot - Inboard Ft. Wish Bone	2	T320	Steering Yoke L. H.	1
T320	Pinot - VP	2	T320	Centre Stud Hd. - Steering	1

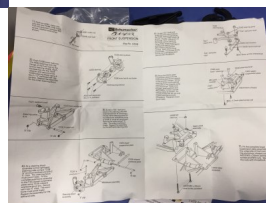

U558 Front suspension Cougar (TopCat to Cougar conversion )

Valutazione: Nessuna valutazione

**Prezzo**

Prezzo base, tasse incluse 129,00 €

Prezzo di vendita 129,00 €

Sconto

[Fai una domanda su questo prodotto](#)

Produttore [Schumacher](#)

**Recensioni**

Nessuna recensione disponibile per questo prodotto.